

Basic Pedestal

Standard Centrifugal Pump

Model 6510A60-B

Size 12" x 10"



PUMP SPECIFICATIONS

Size: 12" x 10" 305 mm x 254 mm) Flanged.

Casing: Ductile Iron 65-45-12.

Maximum Casing Pressure 351 psi (2420 kPa).*

Maximum Operating Pressure 250 psi (1723 kPa) at Temperatures up to 100 F (37 C) Based on System Component Limitations.*

Enclosed Type, Four Vane Impeller: Ductile Iron 80-55-06.

Handles 2" (50,8 mm) Diameter Spherical Solids.

Suction Spool: Gray Iron 30.

Impeller Shaft: Alloy Steel 4150.

Replaceable Wear Rings: Ductile Iron 65-45-12.

Pedestal: Gray Iron 30.

Seal Plate: Ductile Iron 65-45-12.

Shaft Sleeve: Stainless Steel 303/304.

Radial Bearing: Open Single Row Ball.

Thrust Bearing: Open Double Row Ball.

Bearing and Seal Cavity Lubrication: SAE 30 Non-Detergent Oil.

Gaskets: Vegetable Fiber, Red Rubber and Buna-N.

O-Rings: Buna-N.

Hardware: Standard Plated Steel.

Bearing and Seal Cavity Oil Level Sight Gauges.

**Consult Factory for Applications Exceeding Maximum Pressure and/or Temperature Indicated.*

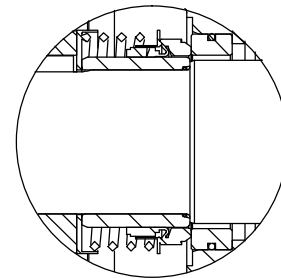
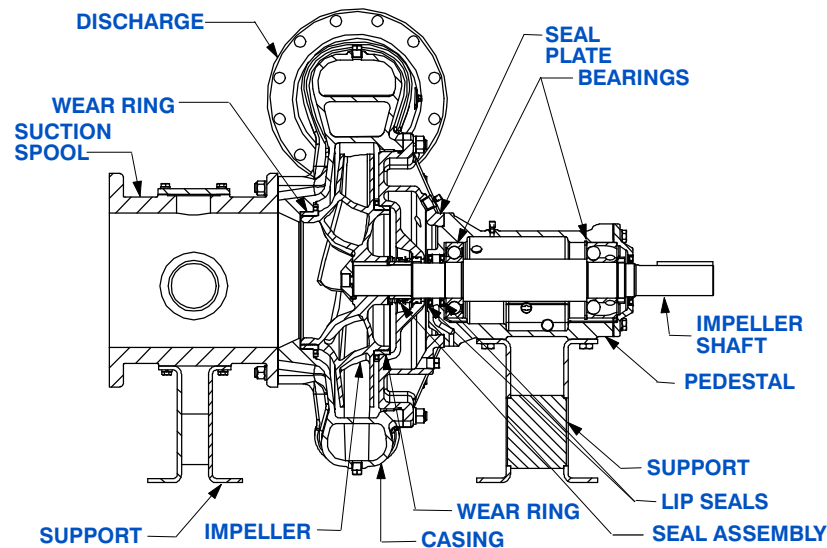

SEAL DETAIL

Mechanical, Oil-Lubricated. Silicon Carbide Rotating Face and Stationary Seat. Fluorocarbon Elastomers (DuPont Viton® or Equivalent). Stainless Steel 316 Cage and Stainless Steel 18-8 Spring. Maximum Temperature of Liquid Pumped 160° F (71° C).*



GORMAN-RUPP PUMPS

www.grpumps.com

Specifications Subject to Change Without Notice



Turoteknikk Drift AS, Hildertunet 2, N-1341 Slependen, Norway
+47 67806300—mail@turoteknikk.no—www.turoteknikk.no

Specification Data

SECTION 65, PAGE 500

APPROXIMATE
DIMENSIONS and WEIGHTS

NET WEIGHT: 1444 LBS. (654,9 KG.)
SHIPPING WEIGHT: 1744 LBS. (791,1 KG.)
EXPORT CRATE: 89.6 CU. FT. (2,5 CU. M.)

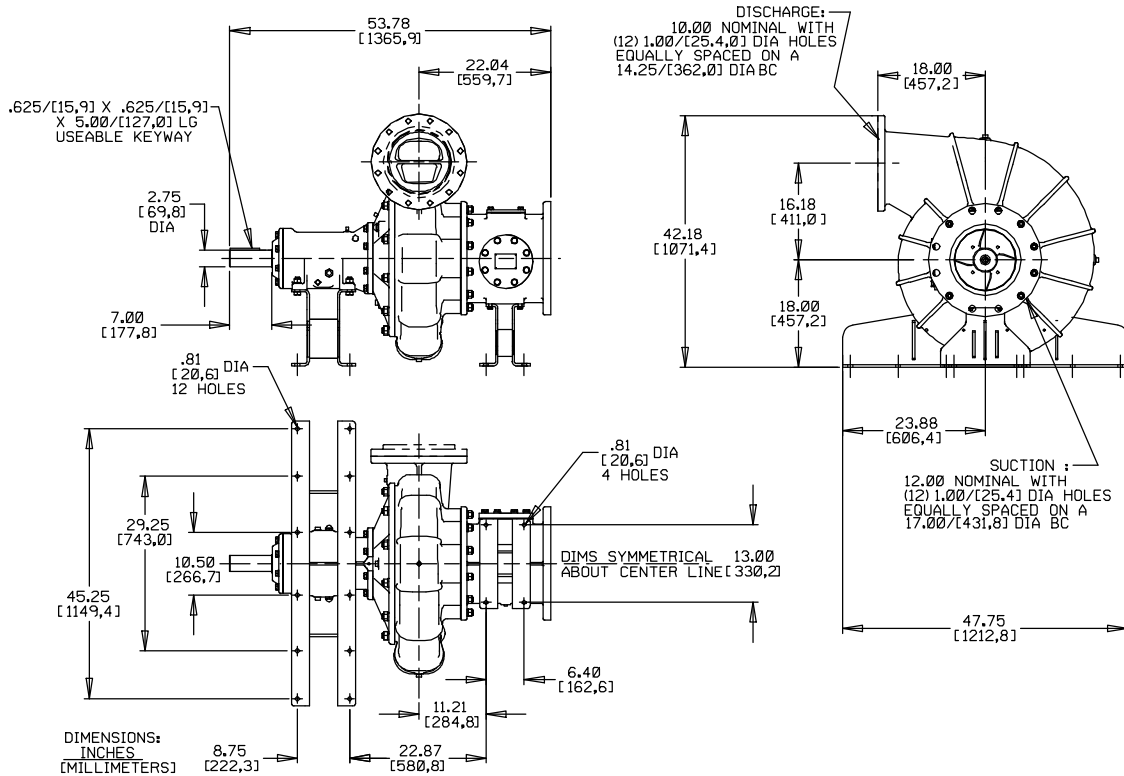

**MULTI-SPEED
CURVE
PERFORMANCE
BASED ON
WATER**

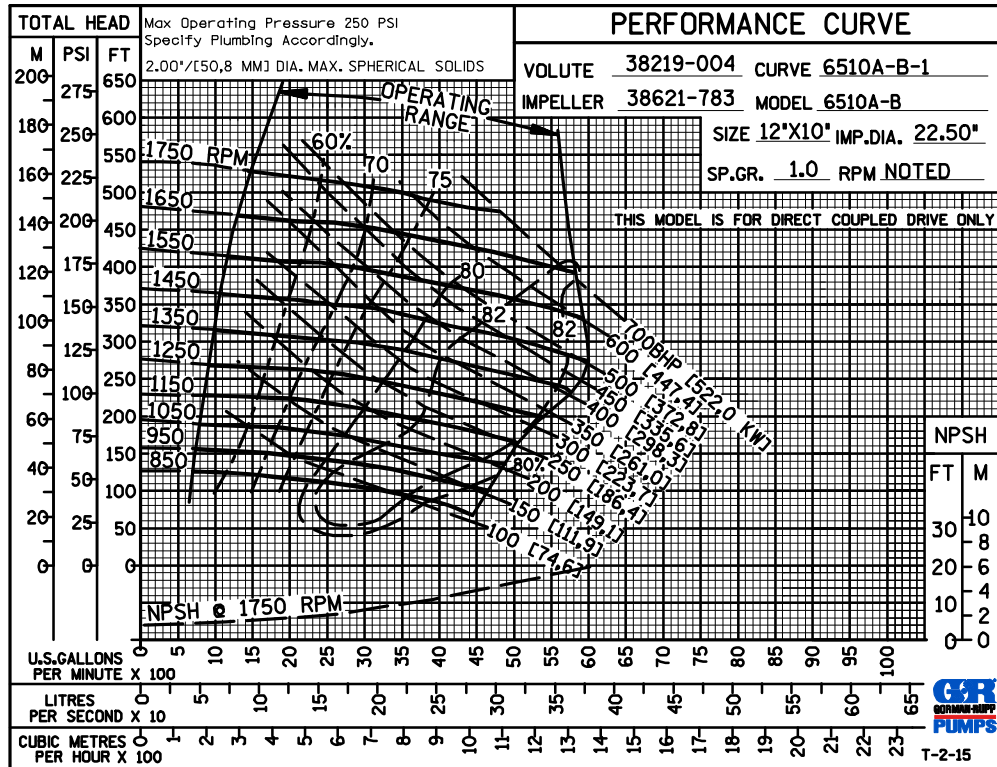

GORMAN-RUPP PUMPS

www.grpumps.com

Specifications Subject to Change Without Notice



Turoteknikk Drift AS, Hildertunet 2, N-1341 Slependen, Norway
+47 67806300—mail@turoteknikk.no—www.turoteknikk.no

60 HERTZ
PERFORMANCE
BASED ON
WATER
TRIMMED
IMPELLER

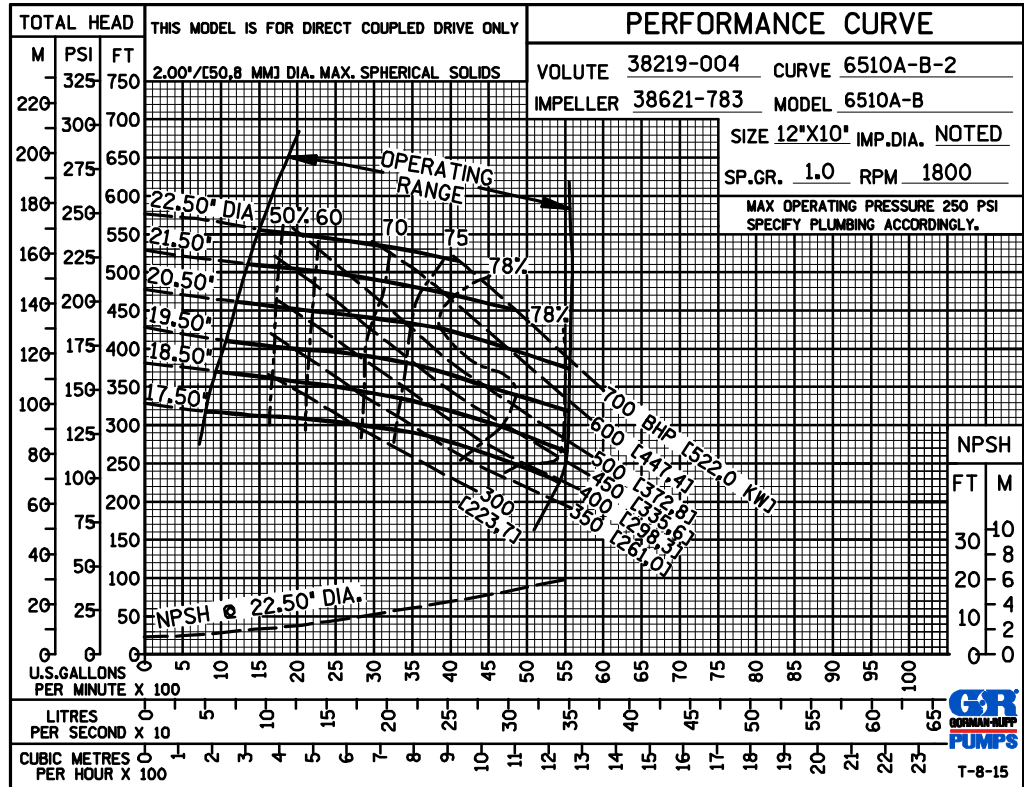

60 HERTZ
PERFORMANCE
BASED ON
WATER
TRIMMED
IMPELLER

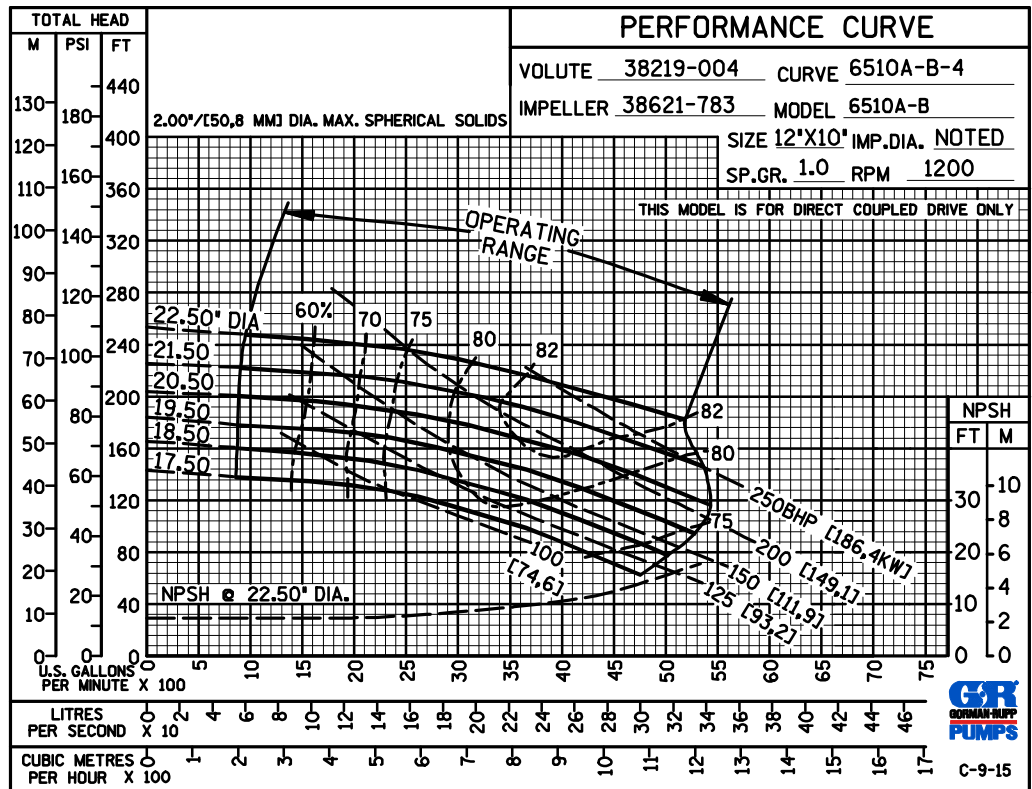

GORMAN-RUPP PUMPS

www.grpumps.com

Specifications Subject to Change Without Notice



Turoteknikk Drift AS, Hildertunet 2, N-1341 Slependen, Norway
+47 67806300—mail@turoteknikk.no—www.turoteknikk.no

50 HERTZ
PERFORMANCE
BASED ON
WATER
TRIMMED
IMPELLER

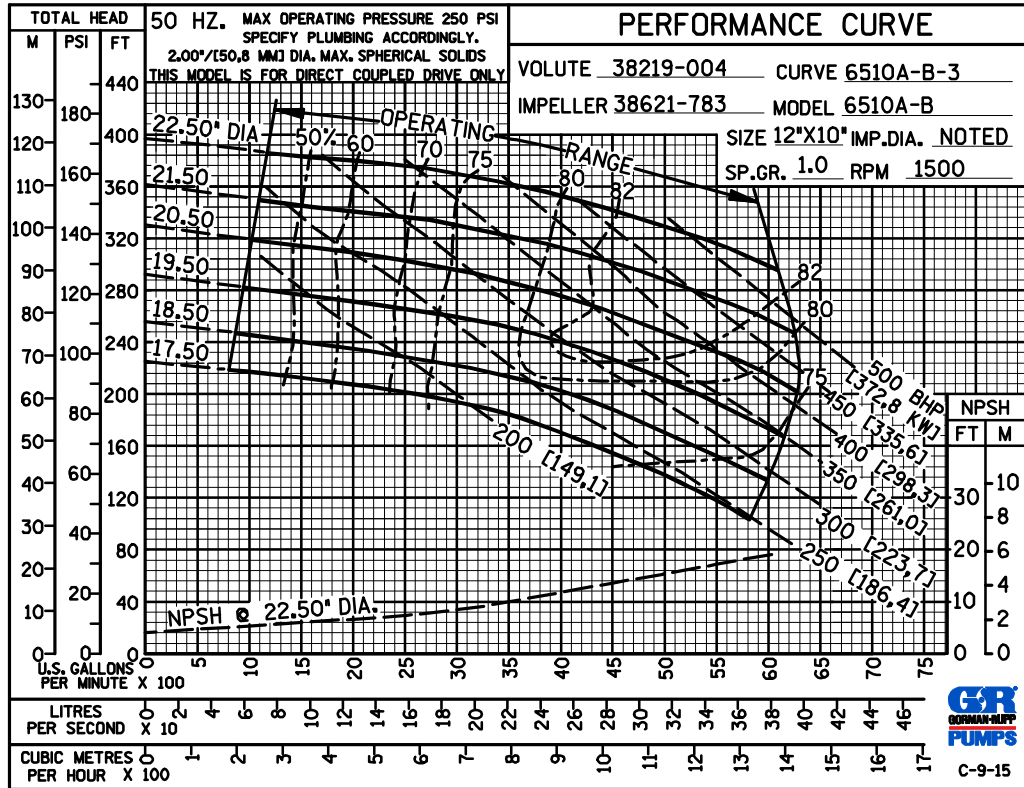

GORMAN-RUPP PUMPS

www.grpumps.com

Specifications Subject to Change Without Notice



Turoteknikk Drift AS, Hildertunet 2, N-1341 Slependen, Norway
+47 67806300—mail@turoteknikk.no—www.turoteknikk.no