

# TV-amplifier A 3240

A 3240 broadband TV amplifier covers all international TV-frequencies. It is intended for use in smaller CAS-systems. The automatic Level Control (ALC) circuit sets the output signal to an appropriate level protecting receivers from overloading in areas close to transmitters. The amplifier is constructed with a hybrid circuit in the front-end followed by three epitaxial transistors assuring high intermodulation suppression and low noise. The gain can be set by a 20 dB attenuator.

The automatic level control (ALC) function is indicated by the front panel LEDs. The green LED is lit when the ALC is off and max. gain is available. The two red LEDs indicate ALC in action in the lower or higher attenuation level.

## TECHNICAL SPECIFICATIONS

Frequency Range:	40–70 MHz 170–230 MHz 470–890 MHz
Gain:	40–70 MHz, TYP 37dB 170–230 MHz, TYP 37dB 470–890 MHz, TYP 42dB
Gain Flatness:	<1.5dB within any 7MHz TV Channel
Noise Figure:	10dB
Max output level:	114 dBuV
IMA3–60dB VO (DIN45004B)	
Input/Output impedance:	75 Ohm
Operational temp. range:	-40 – +60 °C
ALC:	0–30 dB
Manual gain adjustment:	0–20 dB
Supply Voltage:	24 V DC
Current consumption:	275 mA (approx)
Return loss 17 dB at 40 MHz:	-1.5 dB/octave

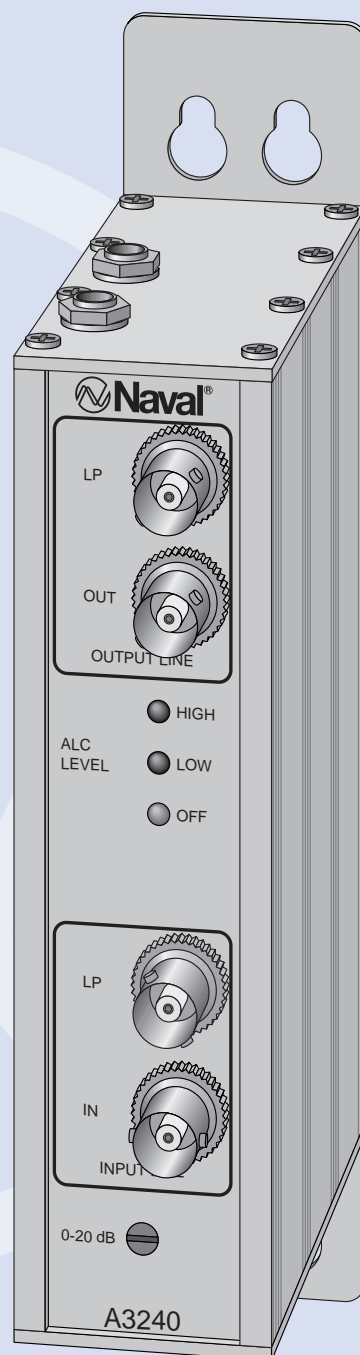

Size: (H) 210 mm x (W) 41 mm x (D) 96 mm

9410

Since 1971, the objective of Naval Electronics has been to offer the best possible products for TV and Radio reception at sea. Naval began with omnidirectional antennas and is the world leader in this field of technology today. Now, with an expanded product range, the name Naval means much more than antennas. Naval operates in more than 40 countries and has installations on thousands of vessels all over the world.

 **Naval**  
Electronics AB

Höjdrodergatan 18, S-212 39 Malmö, Sweden.  
Tel. +46(0)40-29 20 45. Fax +46(0)40-18 74 13.

All specifications stated are subject to change without notice.

6103

# TV-amplifier A 3240

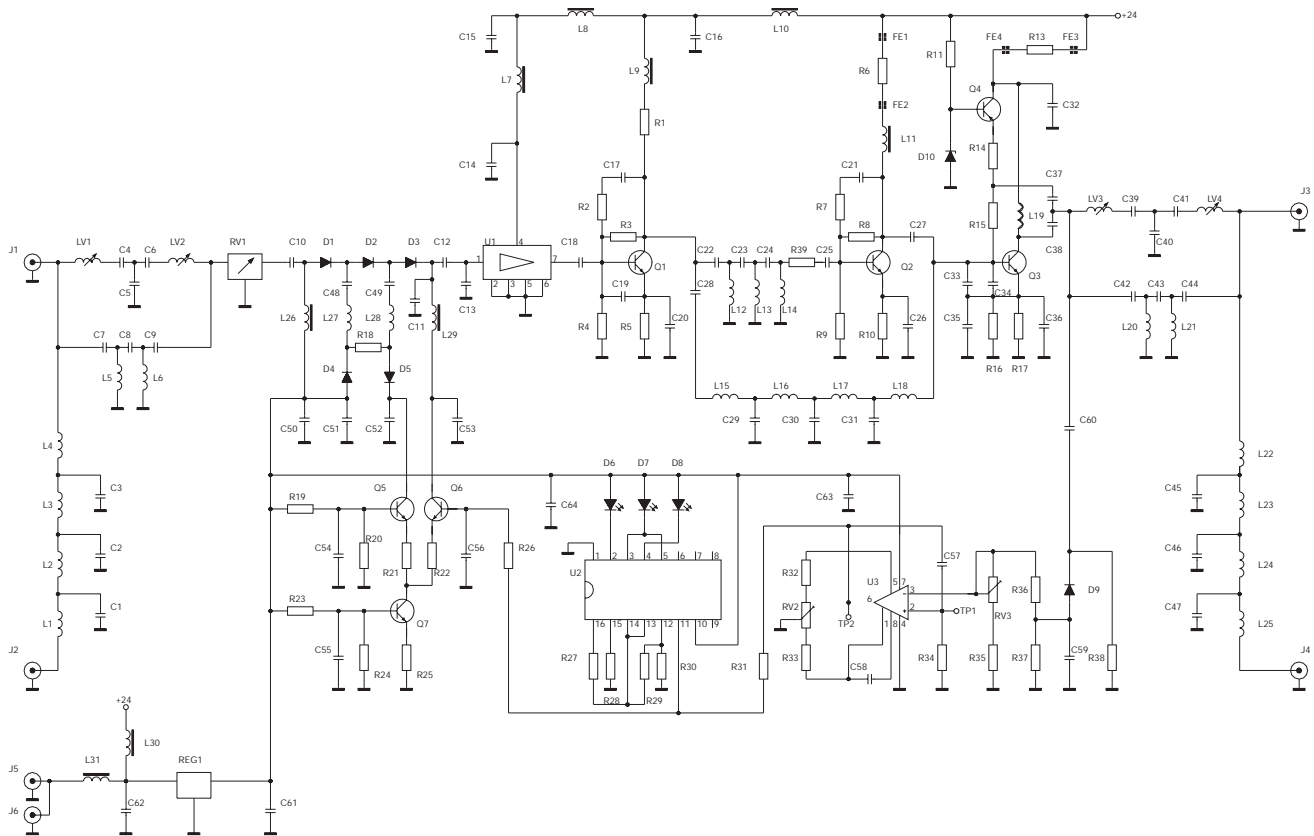

## COMPONENT LIST A 3240

REF.	NAVAL NO.							
R1	680 ohm	111.069	C9	12 pF	125.017	C57	0.022 µF/63V	121.011
R2	270 ohm	111.059	C10	1 nF	125.040	C58	1 nF	
R3	1.2 Kohm	111.075	C11	3.9 pF	125.011	C59	22 nF	130.006
R4	390 ohm	111.063	C12	1 nF		C60	82 pF	
R5	22 ohm SMD	SMD111.033	C13	3.3 pF	125.010	C61	0.1 µF/63V	130.004
R6	270 ohm 2W	113.059	C14	1 nF		C62	0.1 µF/63V	130.100
R7	270 ohm		C15	1 nF		C63	0.1 µF/63V	130.533
R8	1.5 Kohm	111.077	C16	1 nF		D1	BA479G	101.032
R9	390 ohm		C17	1 nF		D2	BA 479G	
R10	18 ohm SMD	SMD111.031	C18	82 pF	125.027	D3	BA 479G	
R11	680 ohm		C19	2.2 pF SMD 0805	SMD125.008	D4	BA 479G	
R12	Replaced by D10		C20	33 pF SMD 0805	SMD125.009	D5	BA 479G	
R13	120 ohm 4.2 W	113.051	C21	1 nF		D6	LED Green 3mm	101.029
R14	2.2 Kohm	111.081	C22	3.9 pF		D7	LED Red 3mm	101.017
R15	220ohm	111.057	C23	3.9 pF		D8	LED Red 3 mm	
R16	10 ohm	111.025	C24	2.2 pF	125.008	D9	AA 119	101.014
R17	10 ohm MELF	114.024	C25	2.7 pF	125.009	D10	11V Zenerdiod	101.051
R18	120 ohm	111.051	C26	33 pF SMD 0805		Q1	BFR 91A	100.002
R19	3.9 Kohm	111.087	C27	33 pF		Q2	BFR 96	100.004
R20	330 ohm	111.061	C28	1 nF		Q3	BFG 34	100.037
R21	100 ohm	111.049	C29	10 pF		Q4	2N2907	100.022
R22	100 ohm		C30	12 pF		Q5	BC 547B	100.012
R23	4.7 Kohm	111.089	C31	22 pF	125.020	Q6	BC 547B	
R24	1.5 Kohm		C32	0.1 µF/63V Wima	121.007	Q7	BC 547B	
R25	22 ohm	111.033	C33	2.7 pF		U1	OM 335	102.002
R26	33 Kohm	111.109	C34	2.7 pF		U2	UAA 170	103.023
R27	10 Kohm	111.097	C35	2.7 pF		U3	CA 3140	103.022
R28	1 Kohm	111.073	C36	3.3 pF		REG1	7812	102.007
R29	18 Kohm	111.103	C37	4.7 pF 1 mod	125.047	RV1	RF-attenuator 75 ohm	115.001
R30	820 ohm	111.071	C38	1 nF		RV2	22 k	115.017
R31	68 Kohm	111.117	C39	33 pF		RV3	2.2 k	115.010
R32	4.7 Kohm		C40	33 pF		L1	0.5x4.0x5.5T	130.005
R33	4.7 Kohm		C41	33 pF		L2	0.5x4.5x9.5T	130.034
R34	68 Kohm		C42	12 pF		L3	0.5x4.5x11.5T	130.036
R35	1 Kohm		C43	6.8 pF		L4	0.5x4.0x5.5T	
R36	100 Kohm	111.121	C44	6.8 pF		L5	0.5x4.0x3.5T	130.003
R37	1 Mohm	111.145	C45	18 pF		L6	0.5x4.0x3.5T	
R38	75 ohm	111.046	C46	18 pF		L7	0.5 µH	131.009
R39	150 ohm	116.053	C47	18 pF		L8	0.5 µH	
C1	18 pF	125.019	C48	1 nF		L9	0.5 µH	
C2	18 pF		C49	1 nF		L10	0.5 µH	
C3	18 pF		C50	10 nF	125.043	L11	0.5 µH	
C4	33 pF	125.022	C51	1 nF		L12	0.6x3.0x1.5T	130.530
C5	33 pF		C52	1 nF				
C6	33 pF		C53	10 nF				
C7	10 pF	125.016	C54	22 nF	125.044			
C8	6.8 pF	125.014	C55	0.1 µF/63V				
			C56	22 nF				

SPARE PARTS			
Transistor	BFR91A	1PCS	100002
Transistor	BFR96	1PCS	100004
Transistor	BC547B	1PCS	100012
RF-hybrid	OM335	1PCS	102002
Attenuator	DR67	1PCS	115001

Sparepart-Kit 202301

Specifications stated are subject to change without notice.