

Power supply and Amplifier PSA 350

The PSA 350 power supply and amplifier is designed to supply power to Mark and VPA series active antennas as well as amplifying radio and TV signals for distribution in a medium-sized network. The power supply accepts 117 and 230 VAC.

The attenuation of each band can be separately controlled. Like all other Naval products, the PSA 350 series are designed to meet the special requirements of worldwide marine use. See overleaf for further details of specific applications.

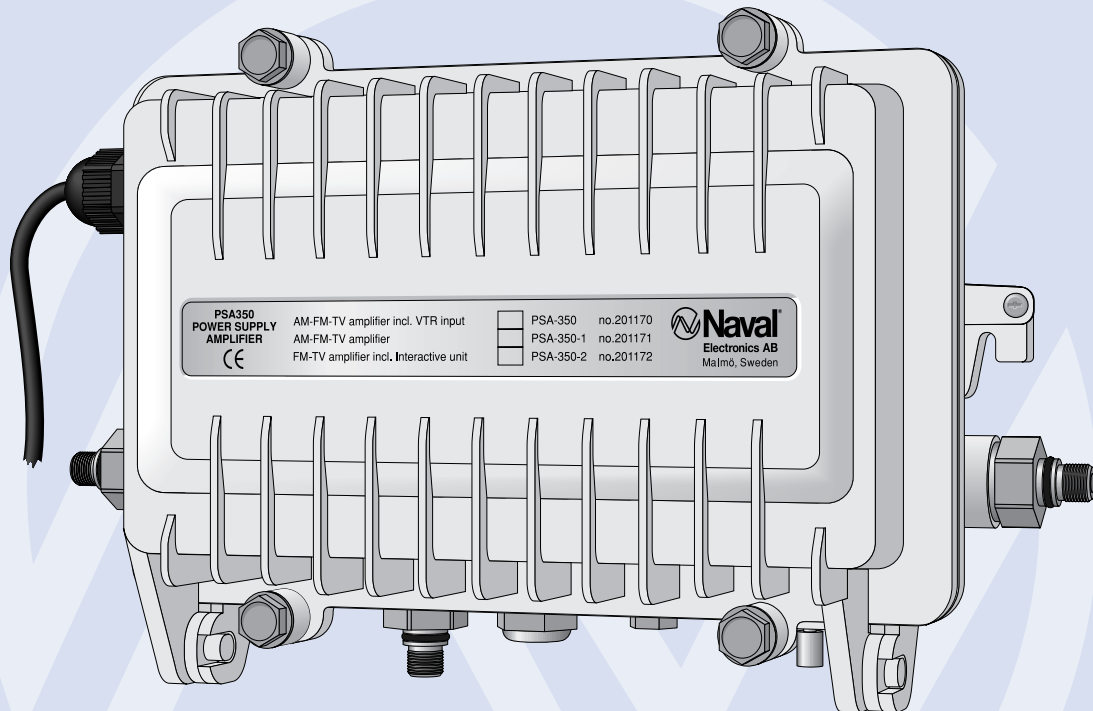

TECHNICAL SPECIFICATIONS

General

Operation temperature range: -40 – +55C°
 Humidity: <95% non condensing
 EMC: EN 50083-2
 Safety: EN 60065

Electrical

Input voltage: 117/230 VAC +10/-15%
 50-60 Hz
 Output to antennas: 15VDC ±5%, Max 300 mA
 Input/Output impedance: 75 ohm
 F-connectors: or 5/8-24
 Frequency range: 0.1-30, and 40-890 MHz
 Gain 40-890 MHz: Operating gain: Min. 27 dB
 Full gain: 34 dB
 Gain 0.1-26.5 MHz: Min. 15 dB
 Noise figure: Max. 7 dB
 Output level, 2 sign 60 dB IMA: Max. 120 dBμV
 Attenuation 0.1-30 MHz: 0-13 dB
 Attenuation 40-890 MHz: 0-18 dB
 Tilt adjustment 40-890 MHz: 0-18 dB

Size: (H) 85 mm x (W) 165 mm x (D) 230 mm

Since 1971, the objective of Naval Electronics has been to offer the best possible products for TV and Radio reception at sea. Naval began with omnidirectional antennas and is the world leader in this field of technology today. Now, with an expanded product range, the name Naval means much more than antennas. Naval operates in more than 40 countries and has installations on thousands of vessels all over the world.

All specifications stated are subject to change without notice.

 **Naval**[®]
 Marine Broadband Communication

Naval Electronics AB
 Höjrodergatan 18, SE-212 39 Malmö, Sweden
 Tel. +46(0)40-29 20 45. Fax +46(0)40-18 74 13
 E-mail: sales@naval.se

5003

Power supply and Amplifier PSA 350

Examples of possible PSA 350 configurations.

The PSA 350 can typically supply 8–16 TV/Radio outlets, depending on cable lengths. The amplifier features low noise and is designed to operate difficult conditions at sea with wide variations in the input signal.

The PSA 350 amplifier works well in standalone medium-sized systems, or as a subamplifier in larger installations equipped with the CAS 3000 main system.

12 TV/radio outlets

The PSA 350 is the ideal solution for medium-sized distribution systems with 8–16 TV and radio outlets.

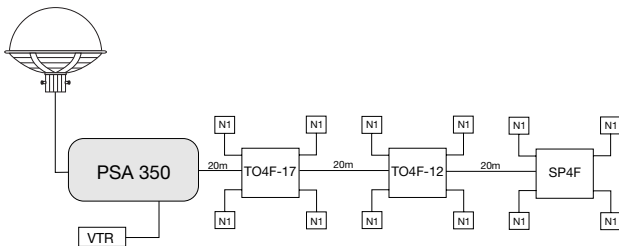

16 TV/radio outlets

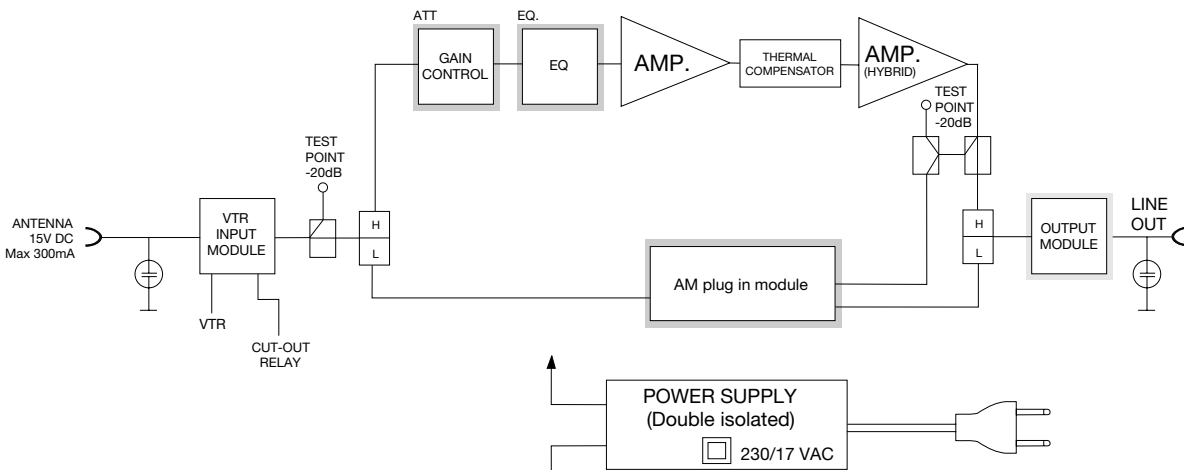
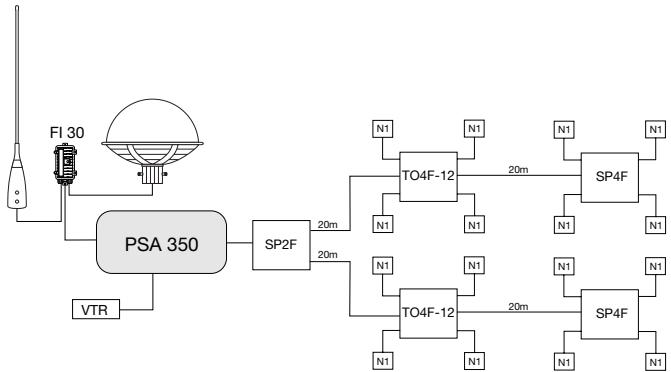

Power supply is approved for class II operation but is equipped with grounded cable as standard

Use as line amplifier

The PSA 350 is also well suited as sub-amplifier in larger systems or as an interactive unit e.g for Pay TV a.s.o (See leaflet 5004).

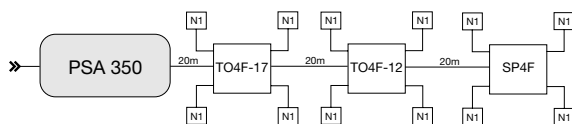

Description	Order No.	Type
PSA 350	201170	AM-FM-TV Amplifier incl. VTR input
		Weight: 1.8 kg
		Standard package: 1
		Volume: 4 dm ³